

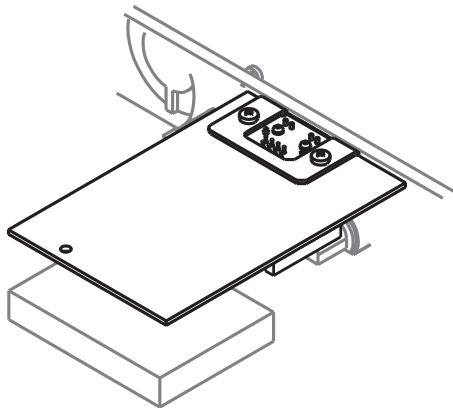

## Dante Interface Board Assembly Diagram for ACT-828 / ACT-848 Receiver

### I. Assembled Diagram



All rights reserved. YM 020/04  
Do not copy or forward without prior approvals MIPRO.  
Specifications and design subject to change without notice.



2CE609A

### Assembly Instructions

### II. Step-by-Step Assembly Instructions

1. Align and screw the connecting fixed plate onto the Dante interface board, Fig. 1.

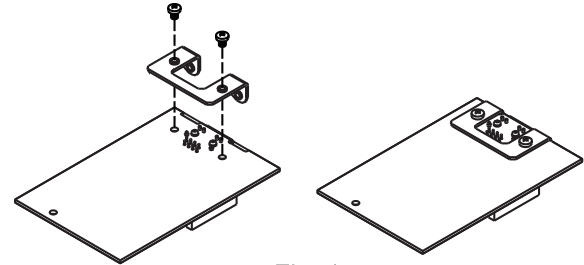

Fig. 1

2. Connect the 20pin FPC cable to Dante interface cable connector and receiver board cable connector. Screw the assembled board onto the rear panel of ACT-828 / ACT-848 receiver, Fig. 2.

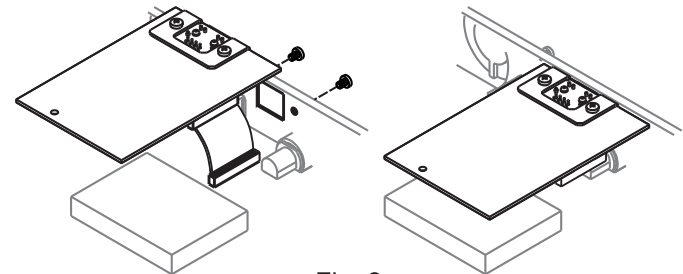

Fig. 2