

### MT-58A 5 GHz Digital Interlinking Transmitter

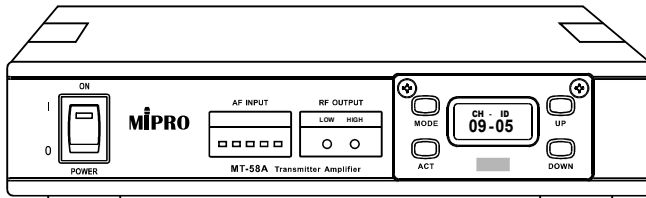

# Parts Name

## Front Panel

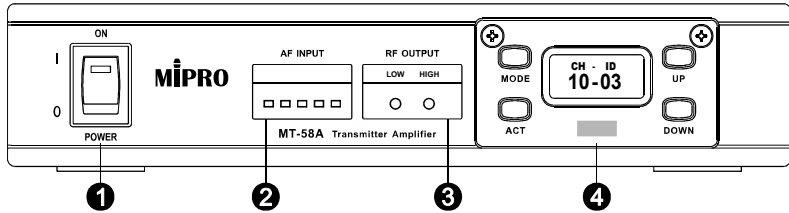

## Rear Panel

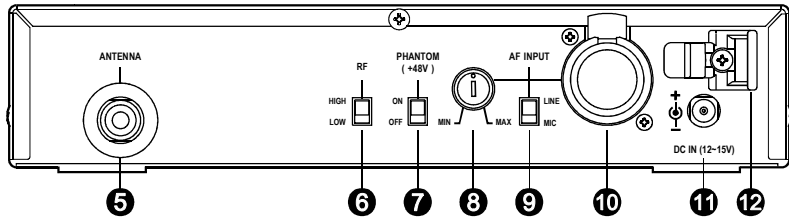

- ❶ Power Switch / Power Indicator
- ❷ AF INPUT Audio Indicator
- ❸ RF OUTPUT Transmission Indicator
- ❹ Wireless Transmitter Control Panel
- ❺ ANTENNA Output Connector (TNC)
- ❻ RF Output Power Selector Switch
- ❼ +48V Phantom Power Switch
- ❽ Audio Input Gain Control Knob
- ❾ Audio Input Sensitivity Switch
- ❿ Balanced / Unbalanced Audio Input Jack
- ⓫ Power Input (DC IN 12 – 15 V, Center Positive (+))
- ⓬ Power Cord Retainer

## Wireless Transmitter Control Panel

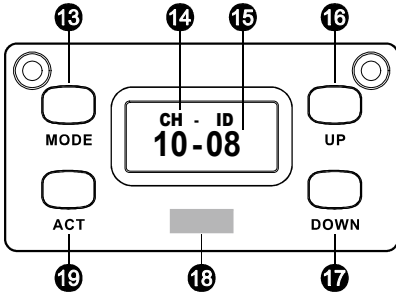

- 13 MODE Button
- 14 Display CH (Channel) & ID (ID Code)
- 15 Parameter
- 16 UP Button
- 17 DOWN Button
- 18 ACT Sync Window
- 19 ACT Button

### Power Supply

Connect the output of a 12 – 15 V DC / 2 A power adapter to the unit's DC power input jack. Use the power cord retainer to secure the power cable and prevent accidental disconnection.

### Antenna Installation

Insert the supplied antenna into the antenna connector on the rear panel and fasten it securely.

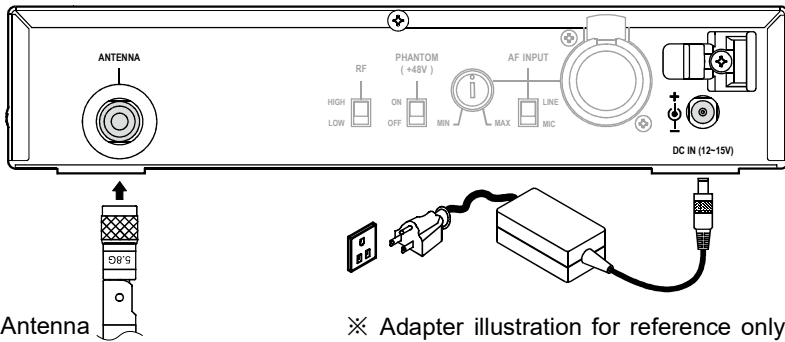

※ Adapter illustration for reference only; actual product may vary.

### Power On

Set the power switch to the ON position. The power indicator will light up immediately.

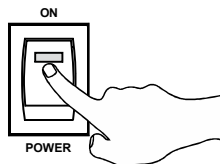

## Panel Operation

### ■ CH – ID: Channel / ID Code

This unit provides **12 preset channels** and **8 ID codes**.

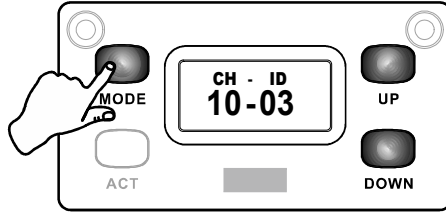

### Channel Setting

1. Press the **MODE** button to switch to the **CH – ID** screen. The left channel digits will flash, indicating channel setting mode.
2. Use the **UP** or **DOWN** button to adjust the channel number. The digits will change sequentially in a loop.
3. When the display stops flashing, the setting is complete.

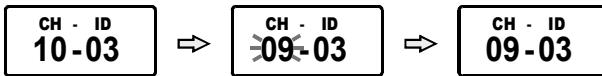

### ID Code Setting

1. After completing the channel setting, press the **MODE** button again to switch to **ID code** setting mode. The right ID code digits will flash, indicating ID code setting mode.
2. Use the **UP** or **DOWN** button to adjust the ID code number. The digits will change sequentially in a loop.
3. When the display stops flashing, the setting is complete.

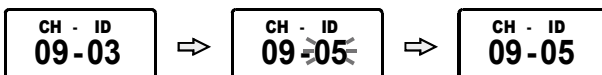

## ■ ACT Function Operation

### Pairing Procedure with Receiver

1. After turning on the receiver, press the **ACT button**. “ACT” will appear on the display.
2. Press the ACT button on the transmitter. “ACT” will appear on its display as well. Move it within 10 cm (about 4 inches) of the receiver’s sensor area and align properly.

### Operation with ACT-5800 Series Receiver

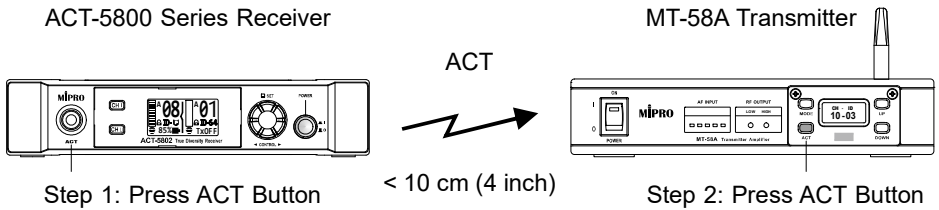

### Operation with MRM-58 Receiver Module

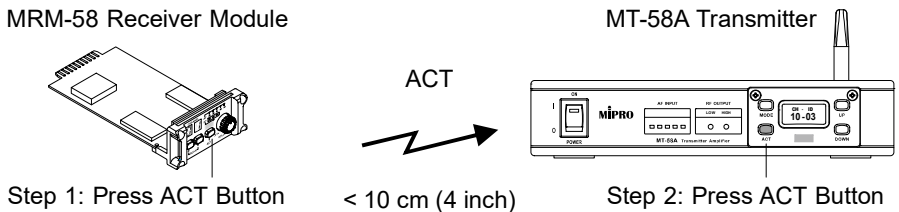

3. If ACT pairing is successful, both receiver and transmitter will display the same **CH - ID**. If no response is received within 20 seconds, “FAIL” will appear, indicating ACT failure.

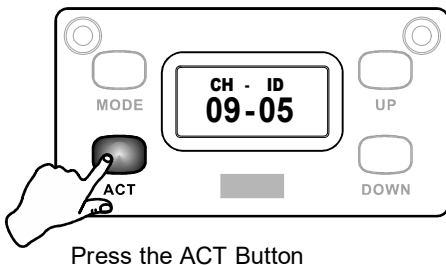

ACT...



CH - ID  
10-05

ACT Success

ACT...



FAIL

ACT Failure

## Rear Panel Operation and Precautions

### ■ Selecting a Suitable Transmitter Amplifier

The RF output power of a transmitter amplifier is generally much higher than that of a wireless microphone. Therefore, before installation and setup, ensure that the connected receiver or other wireless microphone systems can withstand the higher output level. If interference occurs, reduce the RF output power or change the operating frequency.

### ■ Setting RF Output Power

This unit provides **HIGH / LOW** two-level RF output power selection, which can be switched as required. The corresponding **RF OUTPUT** indicator shows the current setting.

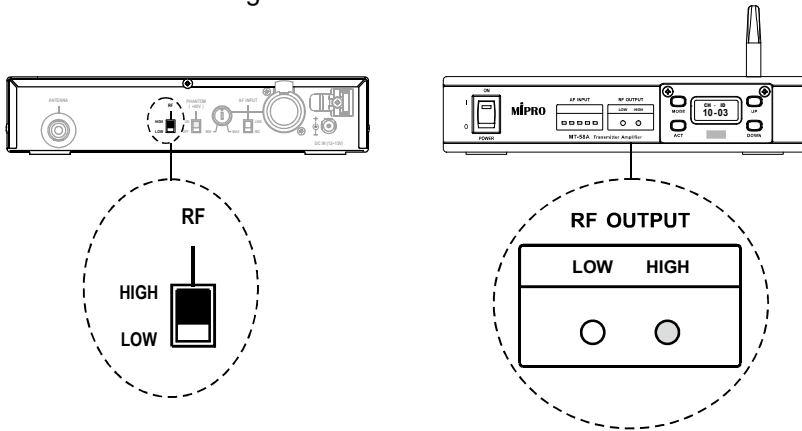

### ■ Setting +48V Phantom Power

The audio input jack of this unit is equipped with **+48V phantom power**, which can be turned ON or OFF as needed.

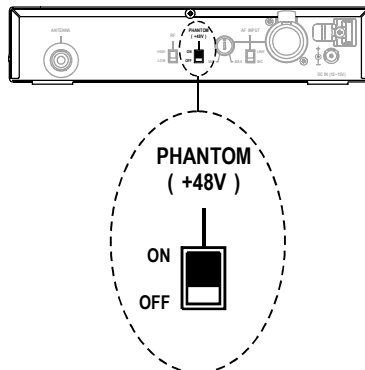

## ■ Proper AF Input Level Setting and Connection

- The **AF input jack** of this unit is designed with a balanced XLR and an unbalanced 6.3 mm phone jack, allowing connection with balanced or unbalanced XLR / 6.3 mm input cables.

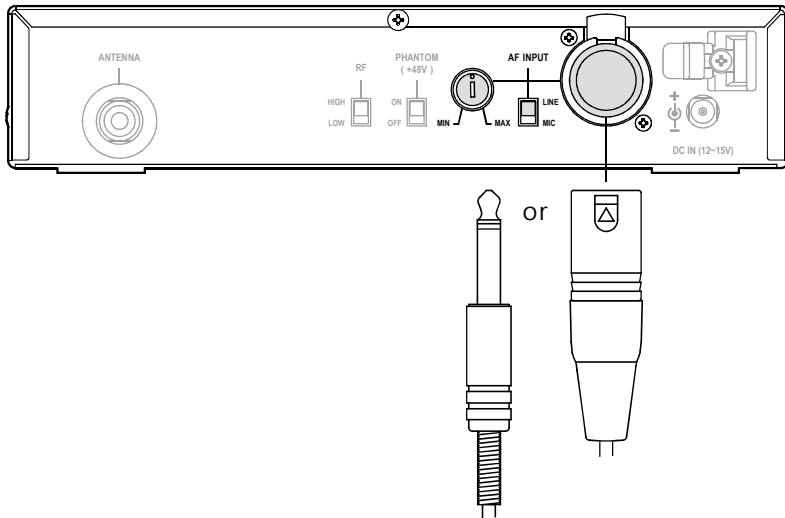

- After connecting the audio signal, the input level must be properly adjusted. The rear panel provides two groups of input controls:

### 1. MIC / LINE Selector Switch

### 2. Audio Input Gain Control Knob

Select the appropriate input sensitivity switch and adjust the input gain control according to the strength of the input audio. If the input level is too high, it may cause distortion and overload. If the input level is too low, the **S/N ratio** will be reduced, resulting in higher background noise. Therefore, it is recommended to set the switch and gain control according to actual requirements to ensure optimum output audio quality.

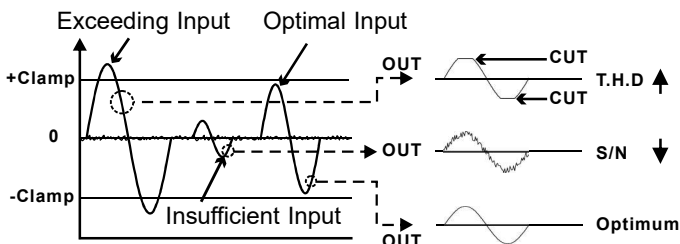

## ■ How to Set the Proper Audio Input Level

- The front panel is equipped with AF INPUT audio indicators that display the current input signal status. The recommended input level is 3 – 4 LEDs lit; if all 5 LEDs are lit, the input level is too high.

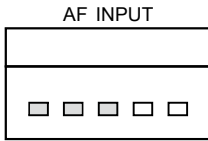

Proper Level: 3 – 4 LEDs Lit



Low Level: 1 – 2 LEDs Lit



Overload Level: 5 LEDs Lit

- The rear panel provides two adjustment methods: an input sensitivity selector switch (MIC LEVEL 0 dB / LINE LEVEL –20 dB) and an input gain control knob.
- **If the input level is too high** (5 LEDs continuously lit):
  - Switch the sensitivity selector to **LINE (–20 dB)**, or
  - Rotate the input gain control knob **counterclockwise to reduce** the input volume.

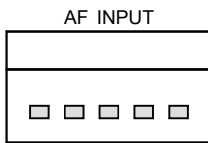

5 LEDs lit

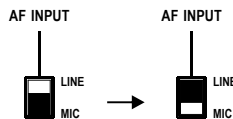

Switch to LINE

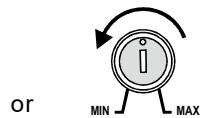

OR

Rotate counterclockwise

- **If the input level is too low** (only 1 – 2 LEDs lit):
  - Switch the sensitivity selector to **MIC (0 dB)**, or
  - Rotate the input gain control knob **clockwise to increase** the input volume.

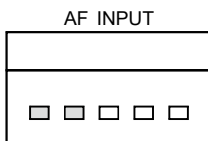

2 LEDs lit



Switch to MIC

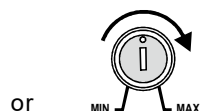

OR

Rotate clockwise

## Notes

1. Refer to the actual product in the event of product description discrepancy.
2. Frequency range, RF output power and maximum deviation comply with the regulations of different countries.



Dispose of any unusable devices or batteries responsibly and in accordance with any applicable regulations.

Disposing of used batteries with domestic waste is to be avoided!



Batteries / NiCad cells often contain heavy metals such as cadmium(Cd), mercury(Hg) and lead(Pb) that makes them unsuitable for disposal with domestic waste. You may return spent batteries/ accumulators free of charge to recycling centres or anywhere else batteries/accumulators are sold.

FC

CE

By doing so, you contribute to the conservation of our environment!

## Federal Communication Commission Interference Statement

This equipment has been tested and found to comply with the limits for a Class B digital device, pursuant to Part 15 of the FCC Rules. These limits are designed to provide reasonable protection against harmful interference in a residential installation.

This equipment generates, uses and can radiate radio frequency energy and, if not installed and used in accordance with the instructions, may cause harmful interference to radio communications. However, there is no guarantee that interference will not occur in a particular installation. If this equipment does cause harmful interference to radio or television reception, which can be determined by turning the equipment off and on, the user is encouraged to try to correct the interference by one of the following measures: . Reorient or relocate the receiving antenna. . Increase the separation between the equipment and receiver. . Connect the equipment into an outlet on a circuit different from that to which the receiver is connected. . Consult the dealer or an experienced radio/TV technician for help.

FCC Caution: To assure continued compliance, any changes or modifications not expressly approved by the party responsible for compliance could void the user's authority to operate this equipment. (Example - use only shielded interface cables when connecting to computer or peripheral devices).

## FCC Radiation Exposure Statement

This equipment complies with FCC RF radiation exposure limits set forth for an uncontrolled environment. This equipment should be installed and operated with a minimum distance of 20 centimeters between the radiator and your body.

This transmitter must not be co-located or operating in conjunction with any other antenna or transmitter.

The antennas used for this transmitter must be installed to provide a separation distance of at least 20 cm from all persons and must not be co-located or operating in conjunction with any other antenna or transmitter.

This device complies with Part 15 of the FCC Rules. Operation is subject to the following two conditions:

(1) This device may not cause harmful interference, and (2) This device must accept any interference received, including interference that may cause undesired operation.

## Industry Canada Statement

This device complies with Industry Canada licence-exempt RSS standard. Operation is subject to the following two conditions: (1) this device may not cause interference, and (2) this device must accept any interference, including interference that may cause undesired operation of the device.

Le présent appareil est conforme aux CNR d'Industrie Canada applicables aux appareils radio exempts de licence. L'exploitation est autorisée aux deux conditions suivantes : (1) l'appareil ne doit pas produire de brouillage, et (2) l'utilisateur de l'appareil doit accepter tout brouillage radioélectrique subi, même si le brouillage est susceptible d'en compromettre le fonctionnement.

## IC Radiation Exposure Statement:

This equipment complies with IC RSS-102 radiation exposure limit set forth for an uncontrolled environment. This equipment should be installed and operated with minimum distance 20cm between the radiator and your body.

Cet équipement est conforme aux CNR-102 d'Industrie Canada. Cet équipement doit être installé et utilisé avec une distance minimale de 20 centimètres entre le radiateur et votre corps. Cet émetteur ne doit pas être co-localisées ou opérant en conjonction avec autre antenne ou émetteur. Les antennes utilisées pour cet émetteur doivent être installés et fournir une distance de séparation d'au moins 20 centimètre de toute personne et doit pas être co-située ni fonctionner en conjonction avec une autre antenne ou émetteur.

**MIPRO ELECTRONICS CO., LTD.**

Headquarters: NO. 814, Beigang Rd., Chiayi City 600079, Taiwan

Tel : +886-5-238-0809

Fax : +886-5-238-0803

[www.mipro.com.tw](http://www.mipro.com.tw)

[mipro@mipro.com.tw](mailto:mipro@mipro.com.tw)

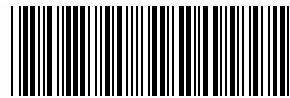

**2CE706A**

All rights reserved. Do not copy or forward without prior approvals of MIPRO.  
Specifications and design subject to change without notice. YM 026/03