

MIPRO

User Guide

ACT-616 UHF Digital Single-Channel Receiver

ACT-626 UHF Digital Dual-Channel Receiver

ACT-646 UHF Digital Quad-Channel Receiver

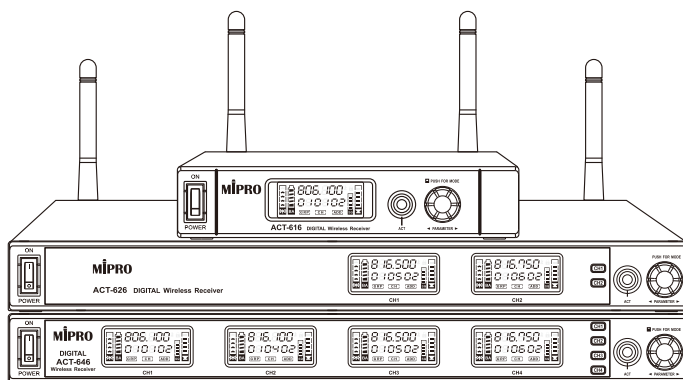

! IMPORTANT SAFETY INSTRUCTIONS !

1. Read these instructions.
2. Keep these instructions.
3. Heed all warnings.
4. Follow all instructions.
5. Do not use this apparatus near water.
6. Clean only with a dry cloth.
7. Do not block any ventilation openings. Install in accordance with the manufacturer's instructions.
8. Do not install near any heat sources such as radiators, heat registers, stoves, or other apparatus (including amplifiers) that produce heat.
9. Do not defeat the safety purpose of the polarised or ground plug: A polarised plug has two blades with one wider than the other. The wide blade is provided for your safety. When the provided plug does not fit into your outlet, consult an electrician for replacement of the obsolete outlet.
10. Protect the power cord from being walked on or pinched particularly at plug, convenience receptacles, and the point where they exit from the apparatus.
11. Only use attachments/accessories specified by the manufacturer.
12. Use only with a cart, stand, tripod, bracket, or table specified by the manufacturer, or sold with the apparatus. When a cart is used, use caution when moving the cart/apparatus combination to avoid injury from tip-over.
13. Unplug this apparatus during lightning storms or when unused for long periods of time.
14. Refer all servicing to qualified service personnel. Servicing is required when the apparatus has been damaged in any way, such as power-supply cord or plug is damaged, liquid has been spilled or objects have fallen into the apparatus, the apparatus has been exposed to rain or moisture, does not operate normally, or has been dropped.
15. To reduce the risk of fire or electric shock, do not expose this apparatus to rain or moisture.
16. Apparatus should not be exposed to dripping or splashing and no objects filled with liquids, should be placed on the apparatus.
17. Use only with the battery which specified by manufacturer.
18. The power supply cord set is to be the main disconnected device.



WARNING



This symbol indicates that dangerous voltage constituting a risk of electric shock is present within this unit.



This symbol indicates that there are important operating and maintenance instructions in the literature accompanying this unit.



This symbol indicates that the receiver should not be opened due to the risk of electric shock. There are no user-serviceable parts inside the receiver. All servicing should be performed by qualified service personnel.



When this equipment is no longer in use, please take it to a public collection point or recycling center for proper disposal.



Parts Name

ACT-616 Single Channel

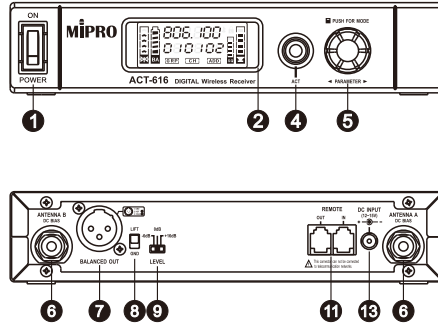

ACT-626 Dual-Channel

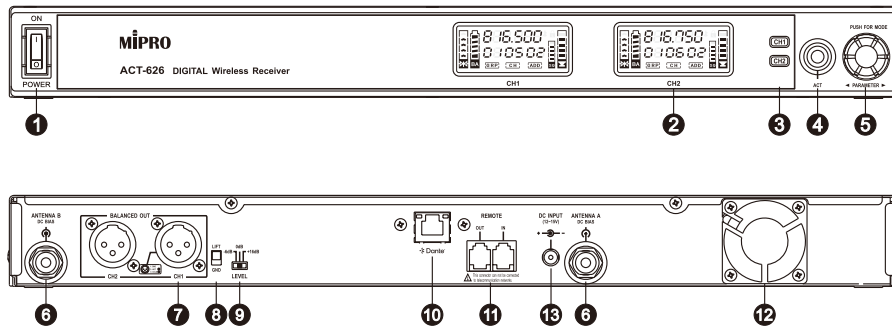

ACT-646 Quad Channel

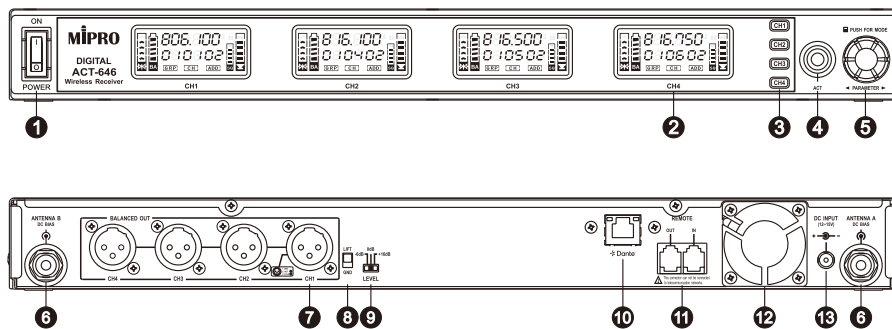

Front Panel

- ❶ **Power Switch:** Turns the power on or off.
- ❷ **LCD Display:** Shows information such as frequency, group, channel, audio level, and RF signal strength.
- ❸ **Channel Selection Button:** Switches the operating channel.
- ❹ **ACT Button:** Activates the ACT sync function to synchronize the transmitter's frequency to the receiver.
- ❺ **Jog Dial:** Press to switch function items or confirm; rotate to adjust function parameters.

Rear Panel

- ❻ **Antenna Connector A / B:** TNC connector used to connect receiving antennas and provide DC bias power.
- ❼ **Balanced Analog Audio Output (XLR):** Provides independent balanced analog signal output for each channel.
- ❽ **Ground Lift Switch:** When set to GND, pin 1 of all XLR connectors is grounded; when set to LIFT, grounding is disconnected. The default setting is GND.
- ❾ **LEVEL Switch:** The balanced output level can be set to three positions: -6 dB, 0 dB, or +16 dB.
- ❿ **Dante Audio Network Interface (optional):** Transmits audio signals via Dante to networked audio devices.
- ⓫ **Computer Network Interface Port:** RJ-11 connector used to connect a computer for system monitoring and parameter configuration.
- ⓬ **Cooling Fan:** Ensures stable heat dissipation performance.
- ⓭ **DC Power Input Jack:** Center pin is positive; input voltage range is DC 12–15V (please refer to the model label for exact specifications).

Receiver Installation and Operation

Installation Environment Recommendations

- Place the receiver in a well-ventilated area, away from heat sources and humidity.
- Avoid placing the receiver near strong electric fields or high-power equipment to ensure stable reception quality.
- When installing in a standard rack, ensure sufficient space for proper heat dissipation.

Antenna Installation and Configuration

- Antennas should be installed onto the antenna connectors located on the rear panel of the receiver.

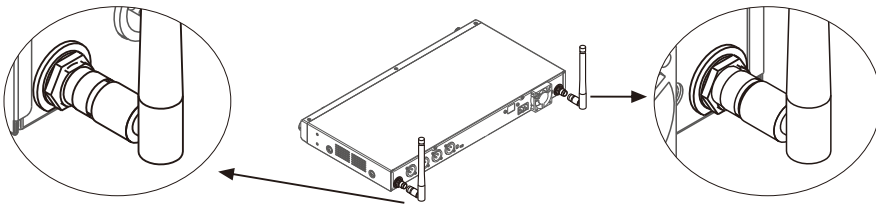

- When the antenna cable length exceeds 10 meters, it is recommended to install an antenna booster to compensate for signal loss.
- The antenna connectors provide built-in DC bias power; avoid prolonged short circuits.
- If the receiver is installed inside a rack, it is recommended to use antenna extension accessories to relocate the antennas to the front of the rack, preventing signal attenuation caused by metal obstruction.

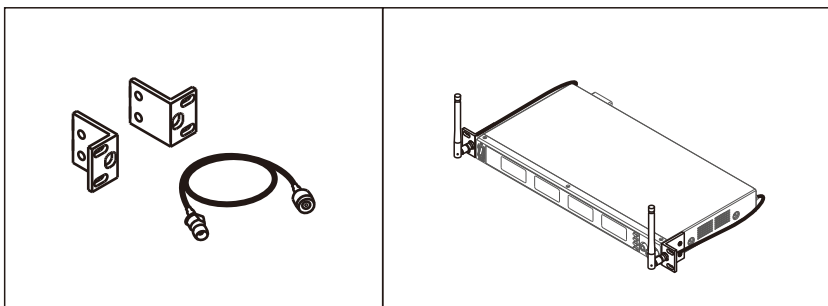

- For optimal reception performance, position the receiver at least 1 meter above the ground, keep a distance of over 1 meter between the antennas and the transmitter, and place them away from strong electric fields or other sources of interference.

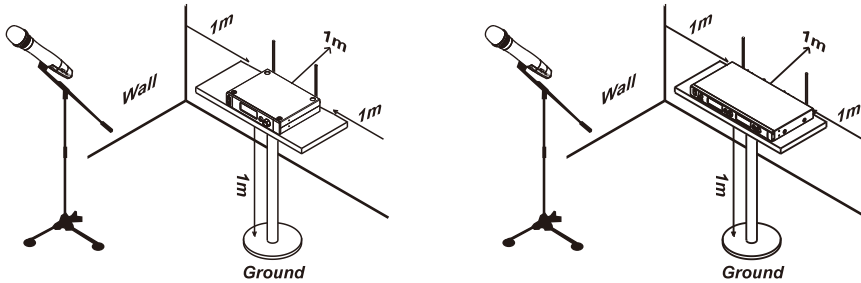

■ Recommendations for Multi-Receiver System Setup

- When using multiple receivers simultaneously, select channels within the same group that are interference-free to prevent signal conflicts.
- It is recommended to use an antenna distributor (such as the AD-708) to share a single pair of antennas, simplifying cabling and improving reception efficiency.
- For long-distance or professional applications, high-gain antennas or antenna boosters may be used to ensure stable signal reception.

■ Rack Mounting Method

- **Half-U or 1U Rack Mount Installation:** Attach the optional rack-mount brackets to both sides of the receiver, then secure the unit directly to the front frame of a standard 19-inch rack.

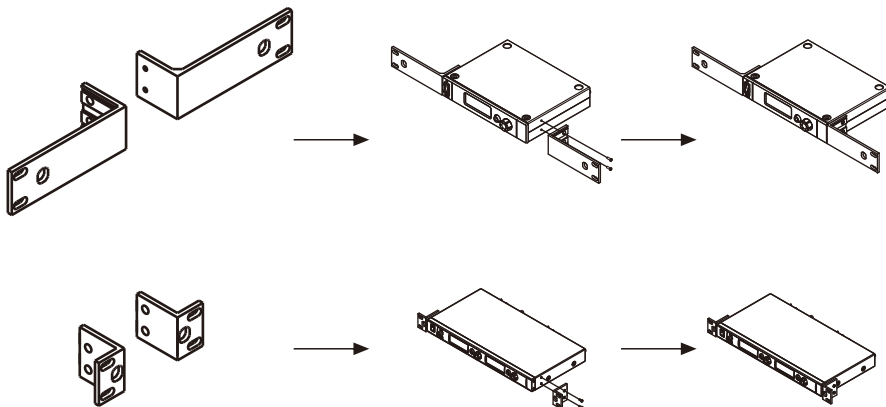

- Dual Half-U Receiver (9.5-inch) Combined Installation: Use the optional joining bracket to connect and combine two half-U receivers into a single 1U receiver unit.

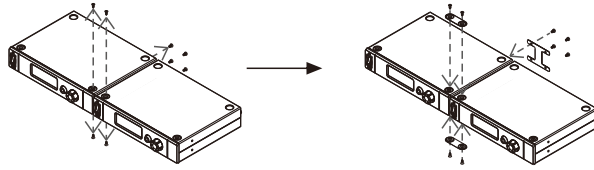

- Secure the left and right 1U rack-mount brackets with screws, then install the receiver directly onto the front frame of a standard 19-inch rack.

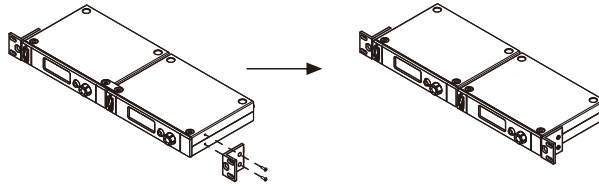

Power Connection

- Use the original power adapter supplied by the manufacturer. Insert the DC plug into the power jack on the rear panel of the receiver (center positive), and connect the other end to an AC outlet to power the unit.
- Please refer to the model label to confirm the input voltage range (DC 12–15V).

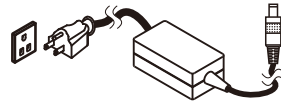

※The power adapter illustration is for reference only.
Please refer to the actual product.

Power-On Procedure

- Set the receiver's power switch to the ON position.
- The LCD screen will light up and display information such as frequency, group, and channel.
- If the screen does not respond, please check that the power adapter and AC outlet are properly connected.

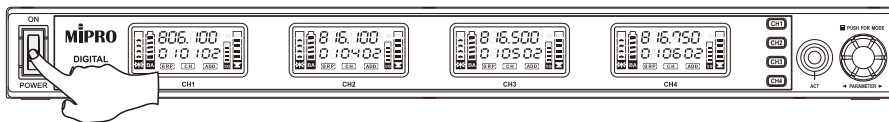

Post-Installation Inspection Steps

- Before turning on the receiver, set the mixer or amplifier volume to the minimum level to avoid sudden loud noises.
- Turn on the corresponding transmitter and bring it close to the receiver to check the LCD display:
 - The RF indicator should light up when the transmitter is turned on.
 - The AF indicator should vary in response to the microphone's audio input level.
- If the RF or AF indicators do not respond, it indicates a system malfunction. Please check all connections and settings.
- Adjust the microphone volume on the mixer or amplifier; no further adjustment is required on the receiver.

LCD Display and Function Description

■ Display Information

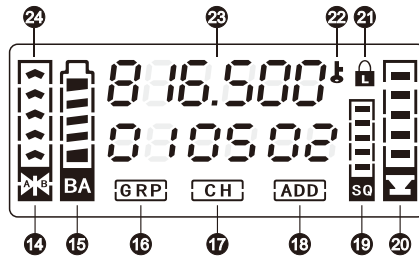

- | | | |
|--|------------------------------------|---------------------------------------|
| 14 Antenna Auto Selection Indicator | 18 PC Remote Control Address | 22 Encryption Indicator |
| 15 Transmitter Battery Level Indicator | 19 Receiving Sensitivity Indicator | 23 Operating Frequency Display |
| 16 Group | 20 Audio Output Level Meter | 24 RF Receiving Signal Strength Meter |
| 17 Channel | 21 Panel Lock Indicator | |

■ Jog Dial Operation Functions

- Rotate the jog dial to change values; press the jog dial to switch options or save settings.
- When operating with the jog dial, the LCD function menu will display in the following sequence:



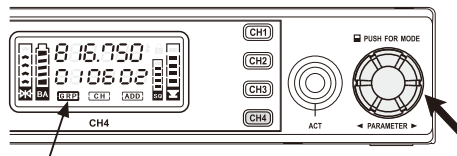

■ Channel and Frequency Settings (GRP / CH / FREQ)

- Press the jog dial to switch between items; when the box flashes, rotate the jog dial to adjust the value.
- The channel (CH) setting has an automatic interference detection function. If interference is present, it will continue stepping down to the next channel until an interference-free channel is found.
- The frequency can be adjusted in steps of 25 kHz or 1 MHz.
- Only the last group allows custom frequency settings; other groups contain fixed channel combinations.
- Press the jog dial again after adjustment to save the settings.



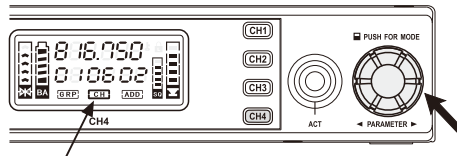

GRP Box Starts Flashing

Rotate clockwise  to change the group number from low to high.
 Rotate counterclockwise  to change the group number from high to low.



CH Box Starts Flashing

Rotate clockwise  to change the channel number from low to high.
 Rotate counterclockwise  to change the channel number from high to low.
 (If interference is detected, it will continue stepping down until an interference-free channel is found.)

■ Antenna Auto Selection Setting

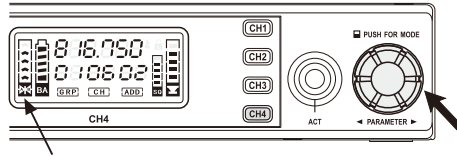

Begins to flash

Rotate the jog dial to switch between three antenna selection modes.

- Press the Channel Selection Button to set the ANT auto-selection mode for each individual channel.
- The factory default is Auto mode. For advanced settings in A or B antenna mode, follow the steps below:
- Press the Jog Dial to enter manual selection mode and cycle through the options. When the ANT indicator begins to flash, press and hold the Jog Dial for about 2–3 seconds until the ANT indicator flashes again. Then rotate the jog dial left or right to select A Antenna, B Antenna, or Auto Selection.



A- Antenna

B- Antenna

Auto



- In manual mode, press the Jog Dial again to exit the manual selection function, or restart the system to return to Auto Selection mode.
- When switching to A or B antenna mode, this function is intended only for installation testing to evaluate the reception performance of each antenna individually. After testing, be sure to revert to Auto Selection mode.

■ ADD: Monitoring Address Setup

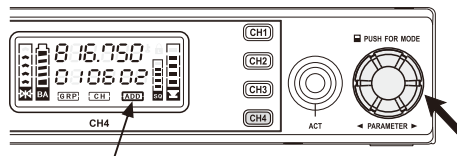
- Each receiver can be assigned a unique address between 01 and 64, allowing the computer's management interface to perform remote monitoring and control.
- When multiple receivers are connected in series, do not assign duplicate addresses; otherwise, monitoring conflicts may occur, preventing proper operation.
- The ADD address setting is valid only when the monitoring function is enabled. If not used, this setting can be ignored.
- Once the address is set, the system automatically stores it and applies it upon the next startup.



ADD Box Starts Flashing

Rotate clockwise  to change the ADD number from low to high.
Rotate counterclockwise  to change the ADD number from high to low.

🔑 : Encryption & Decryption Setup

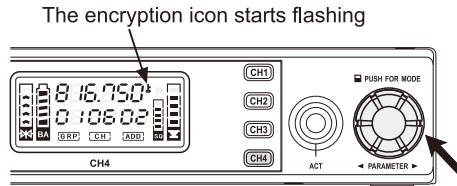

Rotate to select encryption or decryption

- **Encryption / Decryption Setting:** On the receiver panel, press the rotary knob repeatedly to cycle through the menu options. When the encryption icon appears and starts flashing, press and hold the knob for about 2–3 seconds. The display will alternate between **YES** and **no**. When encryption is enabled, the icon 🔑 appears; when disabled (decryption), the icon disappears.





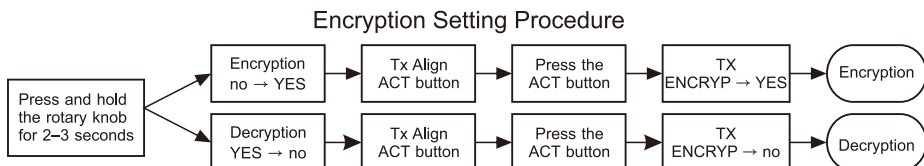

- ****** After changing the encryption status, press the ACT button again to transmit the encryption key to the transmitter.**
- The transmitter itself cannot perform encryption or decryption settings; it can only display whether it is in the encrypted or decrypted state. Therefore, whenever the encryption or decryption setting is changed on the receiver, you must use the ACT function to synchronize the transmitter with the receiver in order to complete the system's encryption or decryption process.
- A transmitter that has been encrypted cannot operate with other receivers. Even if it is on the same frequency, there will be no audio output. Proper system operation can only be restored after performing ACT synchronization again.
- Since the encryption key is generated randomly, pressing the ACT button each time will create a new, unbreakable password.

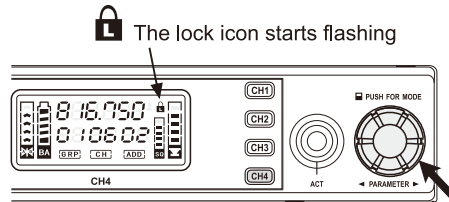

■ Panel Lock / Unlock



Rotate to select Panel Lock or Unlock.



- Press the channel selection key to set panel lock or unlock for each channel individually.
- Panel Lock / Unlock Setting: On the receiver panel, press the rotary knob repeatedly to cycle through the options. When the lock icon  appears and starts flashing, rotate the knob to select Lock or Unlock. During operation, the frequency display will alternately show "0n" and "0FF". To unlock, select "0FF". When pressing the knob, the lock icon stops flashing immediately, indicating that the panel has been successfully unlocked. If the lock icon  does not disappear, the unlock operation has failed. When "0n" is selected and the knob is pressed, the lock icon  continues flashing for about 5 seconds, then stops automatically, indicating that the lock or unlock setting is completed.
- When the lock icon  appears, the receiver panel is locked and all function keys are disabled to prevent accidental operation. To modify or configure new parameters, the panel lock must be released first.

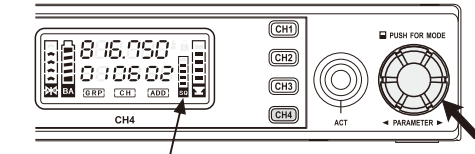

■ SQ:RF Sensitivity Setting



SQ Box Starts Flashing

Rotate clockwise  to increase one step
Rotate counterclockwise  to decrease one step

- Press the channel selection key to set the SQ for each channel individually.
- Rotate the rotary knob and press it when the box highlights SQ. The box starts flashing, indicating that the SQ setting is ready to be adjusted.
- Rotate the knob clockwise to increase one step, or counterclockwise to decrease one step.
- Press the knob again to stop the SQ box from flashing; the new setting will be automatically saved.
- The lower the setting, the higher the receiver's auto-squelch sensitivity. When SQ is set to maximum, the receiver enters manual channel selection mode.
- The SQ setting does not affect the receiver's actual RF sensitivity, regardless of the adjustment level.

■ ACT Synchronization Operation

- Turn on the transmitter power and bring it close to the receiver's ACT sensing area. The distance should not exceed 10 cm.
- Press the receiver's ACT button; the display will enter the "SYNc" synchronization screen.
- If the transmitter synchronizes successfully within 10 seconds, its LCD screen will display the synchronized group and channel numbers.
- At the same time, the receiver display will show stable RF signal strength and battery level indicators.
- If synchronization fails, the screen will display "FAiLEd". Press the ACT button again to retry synchronization.

FAiLEd indicates synchronization failure.

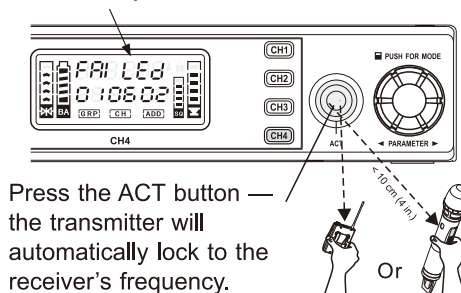

■ Battery Level Indicator

- The receiver display shows the transmitter's battery level in real time.
- When the battery level drops to 1–2 bars, it is recommended to replace or recharge the batteries as soon as possible to avoid signal interruption.

** The actual battery capacity corresponding to each bar may vary depending on the transmitter model. Please refer to the transmitter's user manual for details.

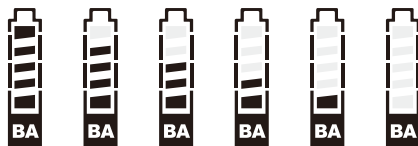

Common Malfunctions and Troubleshooting

| Phenomenon | Possible Cause | Recommended Solution |
|--------------------------------------|---|--|
| No audio output | The transmitter is not matched to the receiver frequency, volume too low, or audio cable not properly connected | Check the frequency pairing and connection status, adjust the mixer volume |
| RF signal present but no AF response | The receiver output is not properly connected, or the mute function is enabled | Check the audio connection or disable mute |
| Audio dropouts or noise | Antenna obstruction, excessive distance, or interference from the same | Adjust antenna angle or change to another frequency |
| AF overload | Input level too high causing distortion | Adjust transmitter volume or switch to lower LEVEL setting |
| Display shows ERR01 | Internal data error | Restart the unit; if the problem persists, contact service center |

* * If the problem still cannot be resolved, please contact an authorized service center or your dealer for technical support.

Computer Control and Network Connection Operation

Use the MIPRO DVU Control Interface (RJ-11)

This unit is equipped with a computer remote monitoring function. It can be connected to a computer via the MIPRO DVU adapter (RJ-11 to USB). When used with the MIPRO Wireless Console software, multiple receivers can be simultaneously monitored and managed.

Connection Architecture and Wiring Description

- Use the included connection cable to link the “Interface Output (OUT)” jack on the rear panel of the first receiver to the “Interface Input (IN)” jack on the second receiver, and continue connecting all receivers in the same manner.
 - Connect the “Interface Input (IN)” jack of the last receiver to the MIPRO DVU adapter, then connect the adapter to the computer’s USB port using a USB cable.
 - Up to 64 channels can be daisy-chained. • The maximum network connection distance is 300 meters; however, for stable data transmission, it is recommended not to exceed 100 meters.
- * * The DVU adapter and RJ-11 dedicated cables are optional accessories and should be purchased according to actual needs.

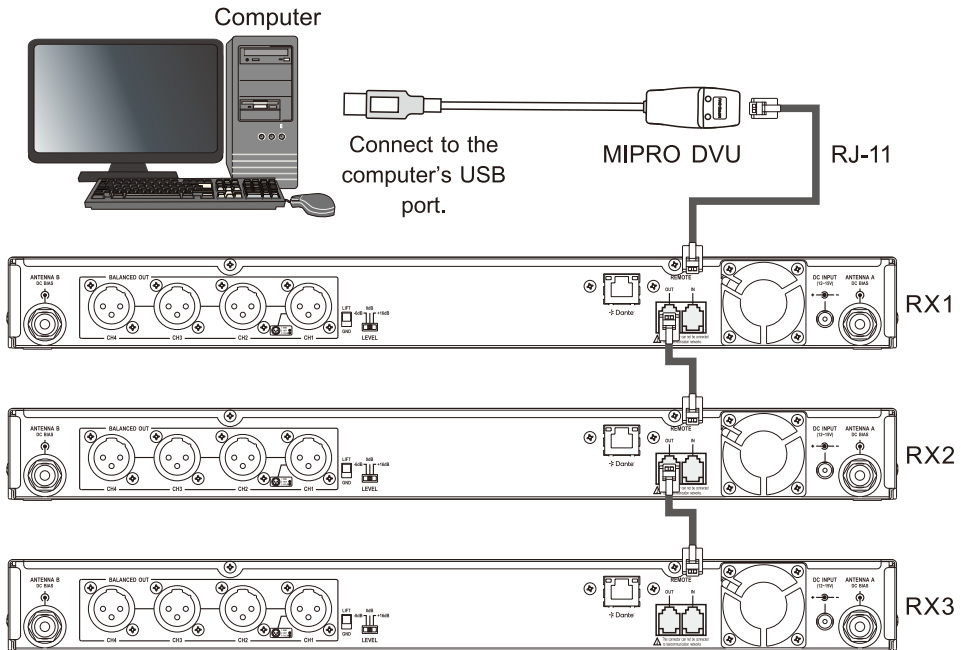

■ Dante Audio Network Operation Instructions (Optional)

This unit can be optionally equipped with a Dante digital audio transmission interface, enabling audio streaming and monitoring over a network. It requires the Dante Controller software to be installed on the computer for operation.

Dante Network Wiring Architecture Description

- Connect the Dante interface on the rear panel of the unit to an Ethernet switch using a Cat.5 / Cat.5e / Cat.6 network cable.
- The Ethernet switch must have a built-in DHCP function or be connected to an external DHCP server (such as a router or IP sharing device) to assign IP addresses.
- Multiple devices can be connected to the same switch and managed collectively through the Dante Controller software on the computer.

Operating Instructions

- Install the Dante Controller software to automatically detect devices over the network, allowing audio stream routing and monitoring configuration.
- For Dante Controller software download and operation instructions, please refer to the official Audinate website:

<https://www.audinate.com/products/software/dante-controller>

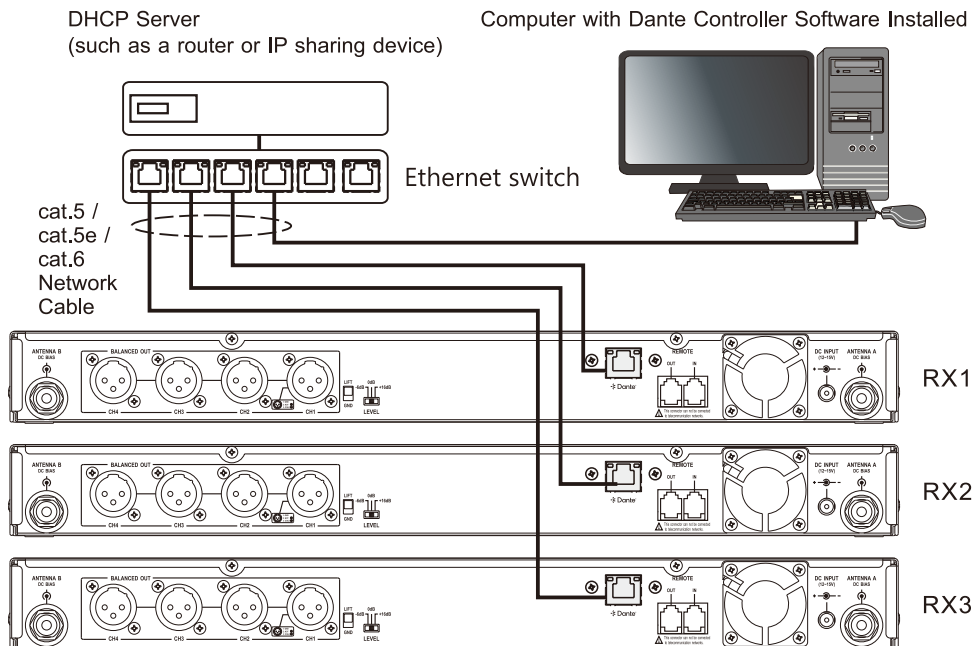

Notes

- Specifications are subject to the actual product.
- The carrier frequency range, output power, and maximum deviation comply with the radio regulations of each respective country.
- To avoid damaging the microphone, do not spray alcohol or liquid cleaners directly onto the microphone capsule. Damage caused by improper cleaning is not covered under the warranty.

MIPRO Electronics Co., Ltd

Headquarters: NO. 814, Beigang Rd., Chiayi City 600079, Taiwan

Tel : +886-5-238-0809

Fax : +886-5-238-0803

www.mipro.com.tw

mipro@mipro.com.tw



2CE703B

All rights reserved. Do not copy or forward without prior approvals of MIPRO.
Specifications and design subject to change without notice. YM 025/12